



DUNLOP EVO 6000





Your Dunlop Table Tennis Table has been designed to give you many years of fun and enjoyment. A little care and attention will extend this period considerably well beyond that covered by the manufacturers guarantee and also ensure your safety and enjoyment. Please read these guidelines, they are to help you and your family get the maximum from your new purchase.

GENERAL

Only use this table after it has been fully assembled, and after checking that the safety systems are working properly.

1. Users must report any defects and faults in the safety systems.
2. Replace immediately faulty parts and do not use the table until it has been fully repaired.
3. Assembly, positioning and storage must be carried out by an adult or under the direct supervision and responsibility of an adult.
4. Do not leave children unattended around the table. The table tennis table is for playing table tennis and should not be used as a toy or for other purposes. Children may put themselves in danger or unforeseeable situations if left unattended. The manufacturer will not be liable for any injury caused through misuse of the table.
5. Any person handling or using this table must follow these instructions and read this notice. The person in charge of assembling and using this table must ensure that the recommendations for use given in this notice are seen by all users. In communal use, it is strongly recommended that the instructions and diagrams are displayed.

ASSEMBLY

The table must be assembled by at least 2 adults following the numerical order of the assembly instructions. (We recommend assembly by our staff at the time of purchase) Before assembling, please check that all the correct parts are contained in the package. The quantities indicated make it possible to go through the operations necessary for each assembly stage.

PRECAUTIONS

INDOOR OR OUTDOOR

1. Only OUTDOOR tables will withstand outside climatic conditions (rain, humidity, frost, sun, etc.). Even with a cover, INDOOR tables can be damaged if used or stored outside. INDOOR tables can warp within hours if left under a hot sun on a summer's day.
2. Moving the table on a sloping surface may cause the table to tip over, damage it or, more seriously, lead to injury.
3. Take the necessary precautions. Do not sit or stand on the table, because of the risk of collapse.
4. Wind may make the table tip over, damage it or, more seriously, cause personal injury. Take the necessary precautions.



5. Take care that children or others do not get their fingers caught when you are opening or closing the table. There is a risk of pinching whilst handling.
6. Always apply the brakes when opening the table because of the risk of the table tipping.
7. It is recommended that you use our protective cover, which will provide additional safety for your children.
8. On uneven surfaces, one or more legs may not rest on the ground. Legs can be adjusted in this case for height. If this does not solve the problem it is recommended that the table is moved to a more level surface. Alternatively ensure the leg is wedged to achieve flatness. If it is not flat the locking devices may not operate smoothly.

MOVING THE TABLE

1. When moving the table ensure the brakes are released or the wheels and your floor may get damaged.
2. It is best to have two people to move the table to ensure the edge of the table, protruding net posts, and your doorways are not damaged.
3. The wheels and subframes are not designed to be bumped downstairs, steps or very uneven ground. Lift the table carefully if such obstacles need to be overcome.
4. On slopes there is an increased risk of the table toppling. Take care!

OPENING THE TABLE

1. Pull the release cord to release the locking pins. Ensure that the pins are released and maintain this action whilst the table is being lowered. Your table is equipped with a safety feature which will stop the table descent half way if the cord is not operated throughout the operation. DO NOT force the table.
2. Make sure the outside legs move outwards as you lower the table – gently pull the cross beam (White bar with Dunlop Sport written on it) as you lower the table to ensure the legs move outwards correctly
3. Lower the table down to the game position. Do not allow it to fall, as this might damage your table and yourself.
4. In some instances if you do not hear the table lock engage raise the tabletop from each side of the net until you hear or see it lock into place.

CLOSING THE TABLE

1. Pull the release cord under the tabletop and maintain this action whilst the tabletop is being lifted. DO NOT force the table if the pins are not unlocked.
2. Lift the tabletop up to its upright storage position.



3. For your safety, check that the tabletop is properly locked on both sides in the vertical position.

Keep these instructions and refer to them during maintenance operations and when ordering spare parts from the parts list on the last page. To facilitate processing of orders for spare parts, indicate the type of table and the date of purchase.

GENERAL MAINTENANCE OF YOUR TABLE

1. The Table Top – this can be cleaned using table tennis table cleaning agent or a few drops of mild washing up liquid in warm water. You should not use any aggressive cleaning materials or chemicals on the top surface.
2. The subframe- can be cleaned with a similar water/detergent mixture as needed.
3. Oil the wheels, locking pins and rollers from time to time to ensure they are running freely. Ensure some oil is applied to the locking pins (2 per side on the lower corner of each half of the table.) These locks slide up and down the steel side rails and will work much more smoothly if kept lubricated.
4. Use a cover on both inside and outside tables to keep them clean and to extend their lives. The life of the covers will also be extended by placing a piece of padding over the corners of the table before putting the cover into position to prevent the corners cutting into the cover.
5. If an outdoor table is to be stored outside throughout the year ensure it is not likely to be moved by strong winds and thus topple over. We suggest a light cord around the table attached to hooks in the wall or fence against which it is stored.

If you have any questions please contact our customer care department on 0207 193 3314

ASSEMBLY REQUIRES TWO PEOPLE

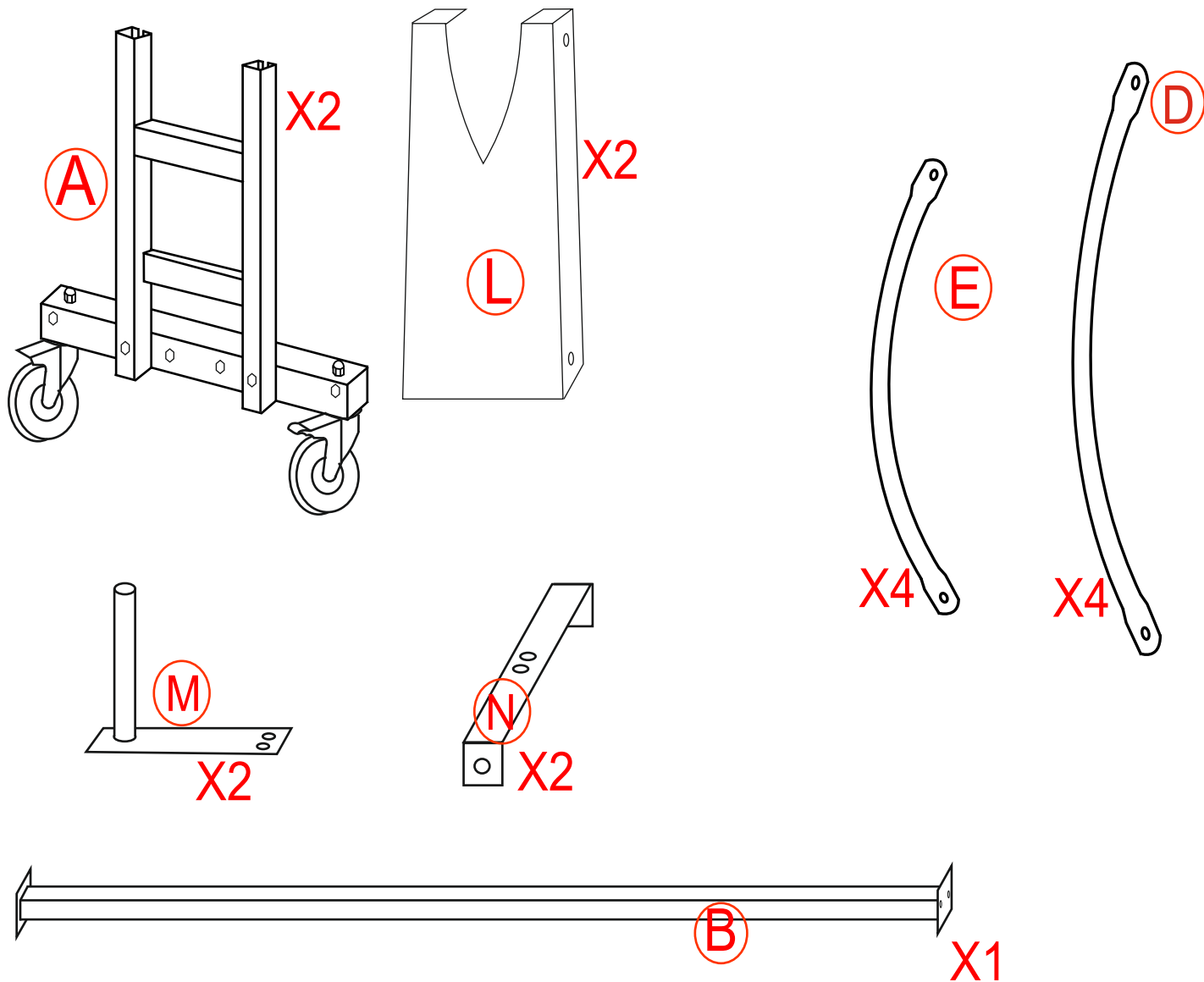

Bolt #A1(4 Pcs.)

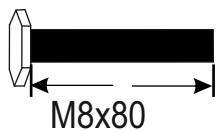

Bolt #A2(4 Pcs.)

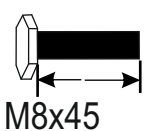

Bolt #A3(4 Pcs.)

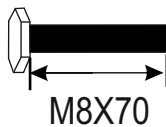

Bolt#A4(4 Pcs.)

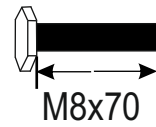

Bolt#A5(4 Pcs.)

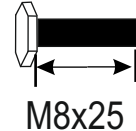

Spacers C1(8 pcs.)

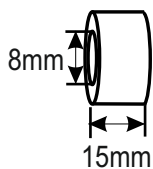

Nuts#B1 (16 Pcs.)

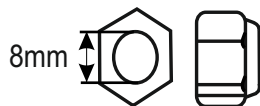

Screw#k2(4 Pcs)

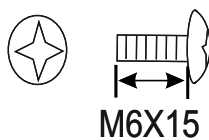

Spacers C2(8 pcs.)

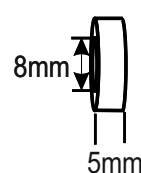

Screw#k1(8Pcs)

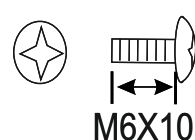

STEP 1

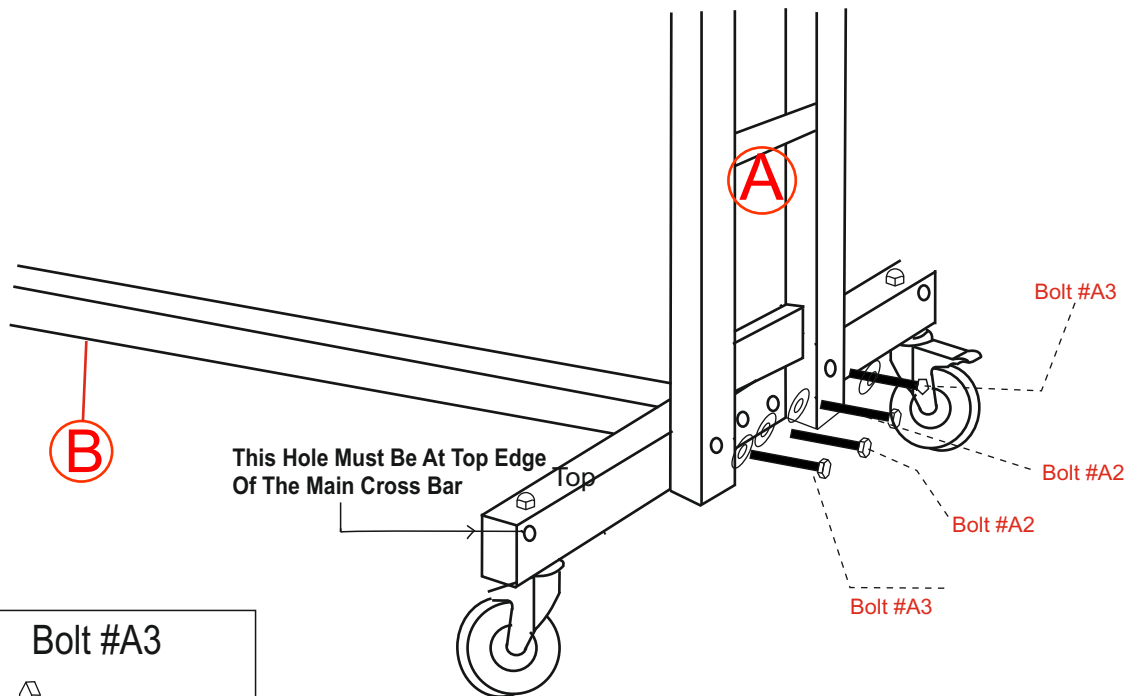

Bolt #A2

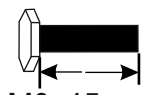

M8x45 X2

Bolt #A3

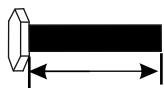

M8x70 X1

STEP 2

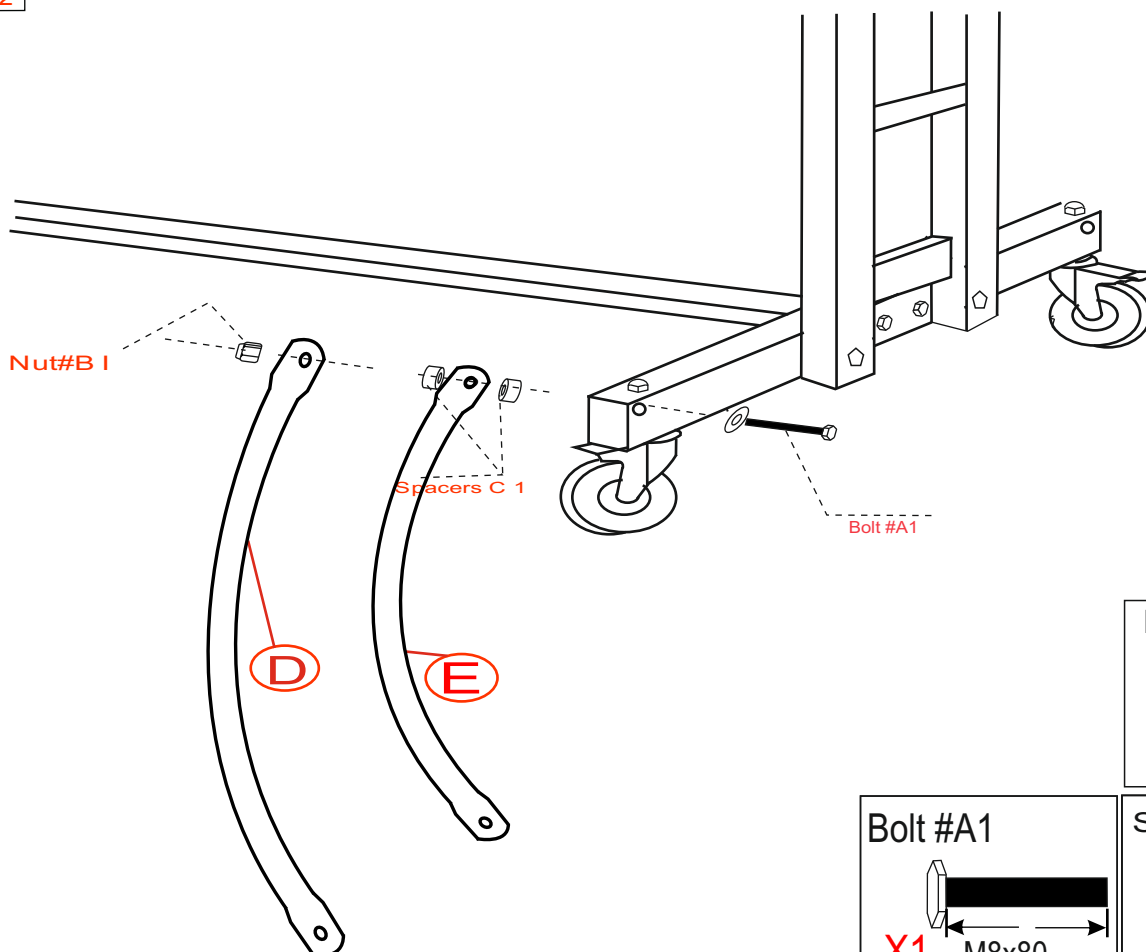

Nut#B1

Spacers C 1

Bolt #A1

Nuts#B1

X1

8mm



Bolt #A1

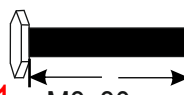

X1 M8x80

Spacer C 1

8mm

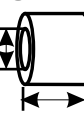



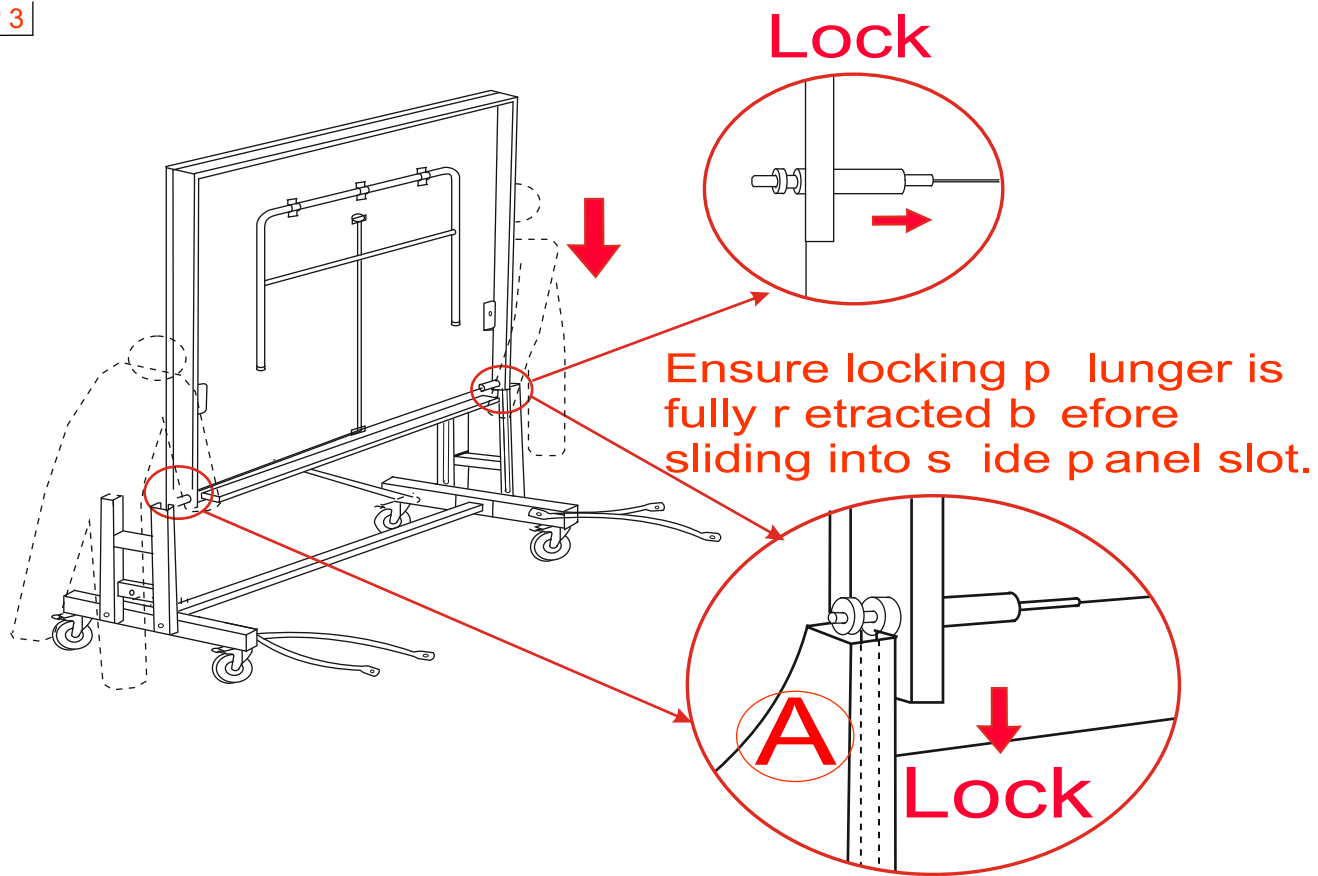

X2 15mm

STEP 3

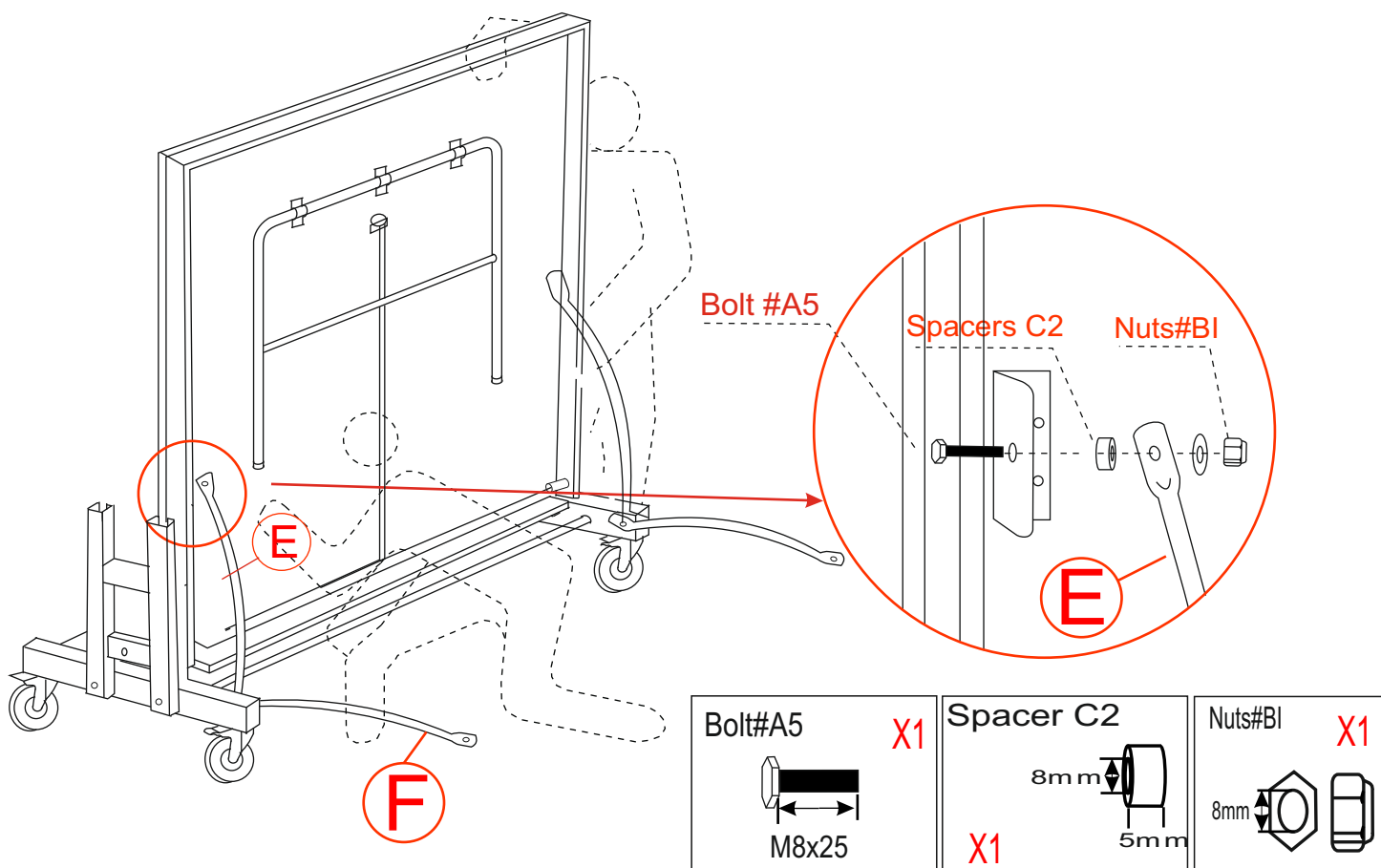

STEP 4

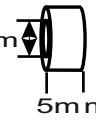

Bolt#A5 X1  M8x25	Spacer C2 X1  8mm 5mm	Nuts#B1 X1  8mm
---	--	---

STEP 5

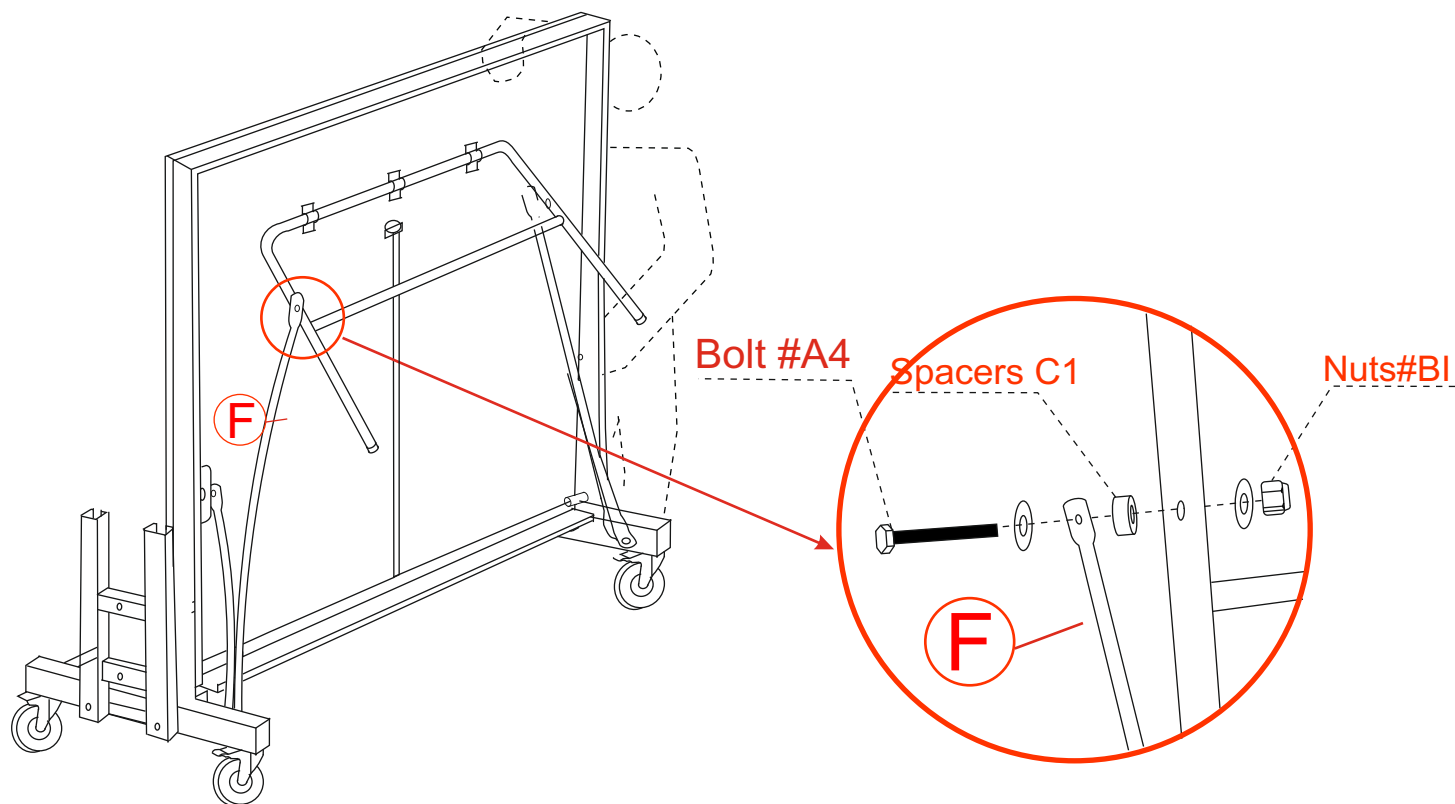

STEP 6

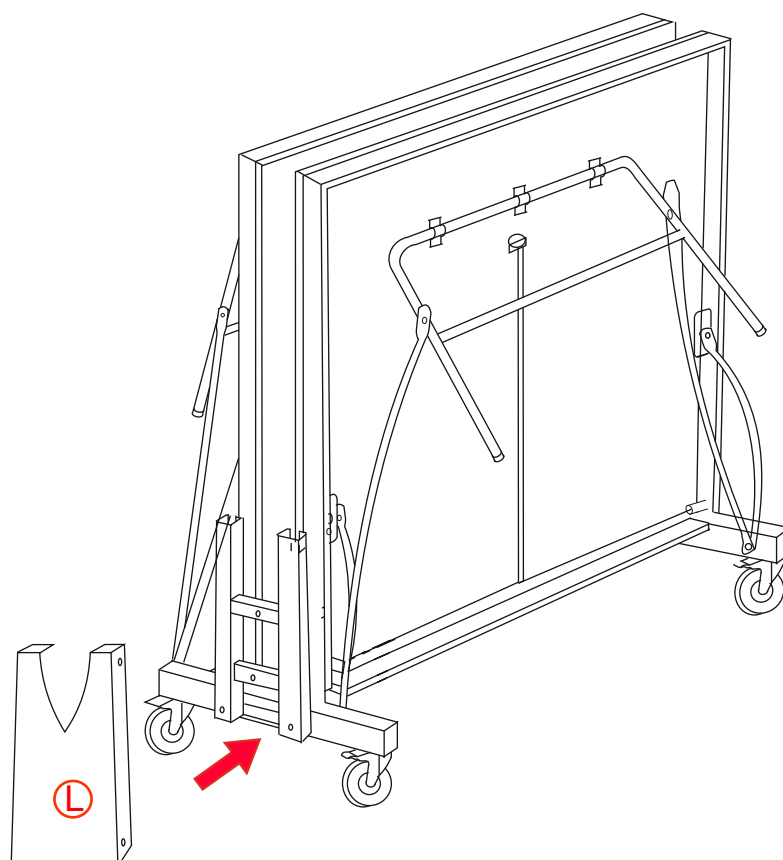

STEP 7

Pull the release string in order to fold or unfold the table. Pull the legs outwards at the same time.

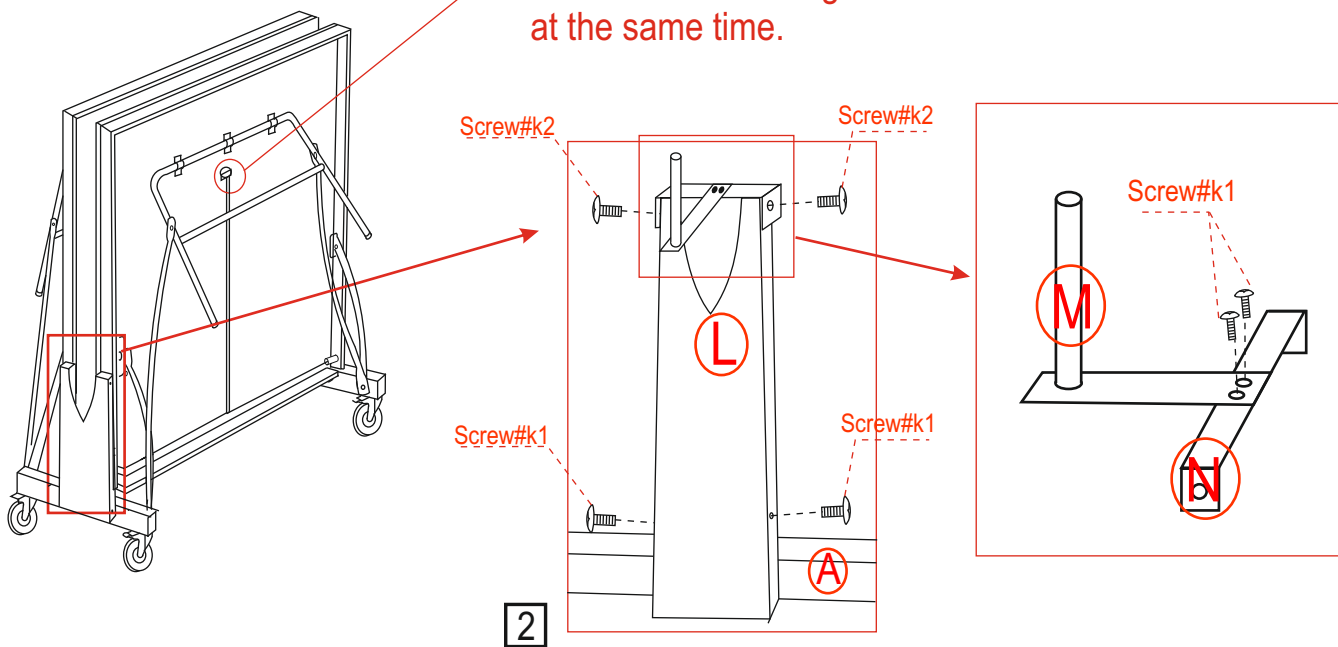

**Remember - Apply Brakes
Before Opening Table.
Never Force Open The Table**

